

# Wide Hysteresis, Precision Threshold Powerful relays

Less than 3  $\mu$ A power supply, making it ideal for portable applications where power supply swings

The EDR82752 belongs to the family of a precision threshold input solid-state relay and intended for voltage monitoring applications. It optimized for battery-power devices and can operate from 1.5V to 5.5V. It incorporates a micro power, precision voltage reference and comparator that allowed by a customer request to set varies threshold voltage and wide hysteresis.

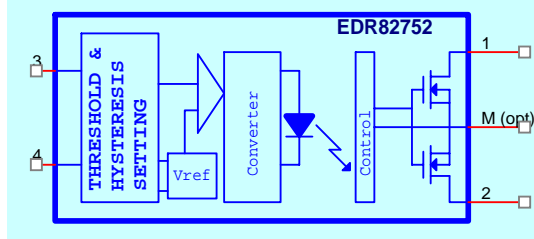

Other features: +/- 1.25% voltage threshold accuracy, immune to brief input transients, fast turn on delay within 2mS and turn-off less than 0.3mS, and various output voltage and current are offered. A threshold and hysteresis are setting during the production.

## Specifications for p/n EDR82752/1 – DT1L60A2/2/04

### Input Specifications:

Input DC Voltage	1.5V to 5.5V
Nominal Current above threshold	10 mA
Maximum current below threshold	3 $\mu$ A

### Typical Output Specifications

Operating DC voltage range	+/-60 VDC/42VAC
Maximum continuous current	2.0A
Maximum surge current (IDM) - 2mS	6.0 A
Maximum on-state resistance	.10
Rising time max.	.8 mS
Delay-on time max.	.25 mS
Falling time max.	0.1 mS
Delay-off time max.	0.3 mS
Maximum switching frequency	300 Hz

\* Test performed at the input current equal to 10 mA

### General Specifications:

Ambient operating temperature range	-40 <sup>o</sup> C to 85 <sup>o</sup> C
Ambient storage temperature range	-55 <sup>o</sup> C to 125 <sup>o</sup> C
Dialectic Strength input-to-output	1,500 V rms

### Mechanical Specifications:

Weight(oz)	.04
Encapsulation	ResTech 10207/053
Dimensions for D2L package	1.15"H x 1.75"L x 0.4"W
Dimensions for DIP24 package	0.375"H x 0.925"L x 0.53"W
Dimensions for D1L package	0.615"H x 1.485"L x 0.29"W
Terminals/solder for DIP24 package	.030" diameter
Terminals/solder for SIP5/4 package	0.40" diameter

### Packaging information and pins-out for a mini SIP4m.

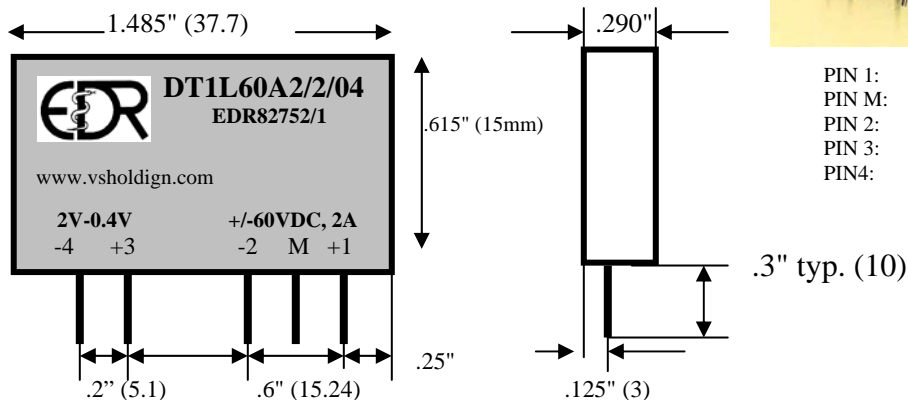

All Dimensions are in inches (millimeters).

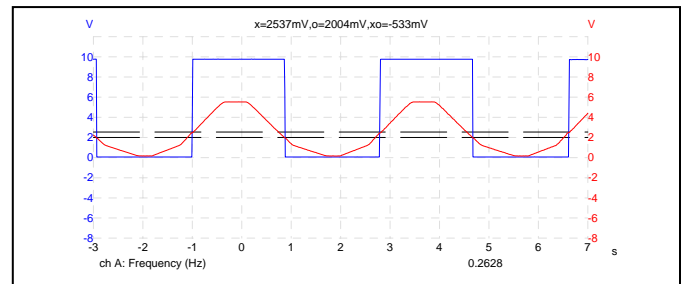
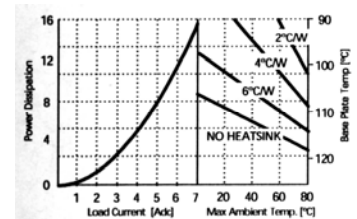
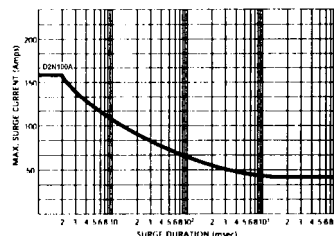
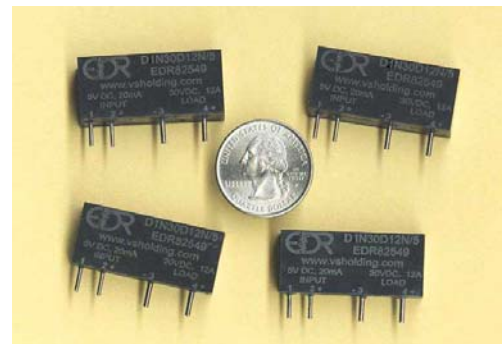

Figure shows the function of the EDR82653



- PIN 1: ~/+ LOAD
- PIN M: - LOAD (optional)
- PIN 2: ~/- LOAD
- PIN 3: + CONTROL
- PIN 4: - CONTROL

## Input Electrical Characteristics (Ta = 25°C) for EDR82752/2 model

Characteristic	Test Condition	Min	Typ.	Max.	Unit
High threshold (turn on voltage)		1.95	2.0	2.05	V
Low threshold (turn off voltage)		1.58	1.6	1.65	V
Current above threshold at 3VDC			5		mA
Current below the threshold			2		μA
Recommended Operating temperature		-40 °C		+ 85	°C
Reverse voltage (max)				-0.3	V

## Switching time test – Load 20 Ohm at 20VDC/1.0A, control 3.3VDC, 10mA

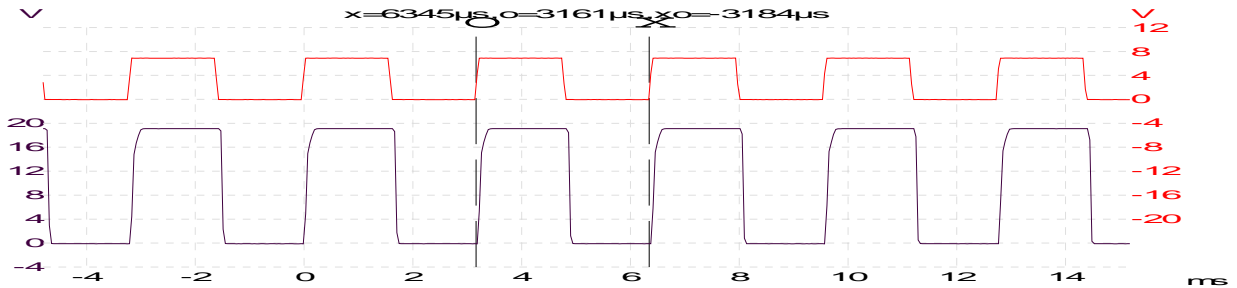

The input of a miniature, a precision threshold input, Solid State Relay built with a micro power circuitry. Input voltage compared against a precision voltage reference and a resulting applied onto the input of a comparator. The comparator forms a control signal to drive a photovoltaic device, which in its turns generates voltage to control output MOSFET (output terminals).

Selecting a proper device for your application should proceed in two steps, which is selecting proper input specifications (low and upper thresholds) and the output ratings (voltage and current). There is none or a little relationship between input and output ratings and they should be satisfied separately. Input threshold voltage and hysteresis will define the device reaction on an input voltage and its fluctuation, and output voltage and current will insure it's a load driving capability. Please let us know what your requirements for a threshold and hysteresis are.

Samples of possible output ratings presented on Page #4. If you would need any other voltage and current, please do not hesitate on requesting a quote.

**In some application, our customer solder directly our devices vie wires to their systems.** We offer color-coded stripped at the end wires of any length. For an AC/DC (+/-Load) output rating an output colors are the same because there is no difference in which order connection is performed.

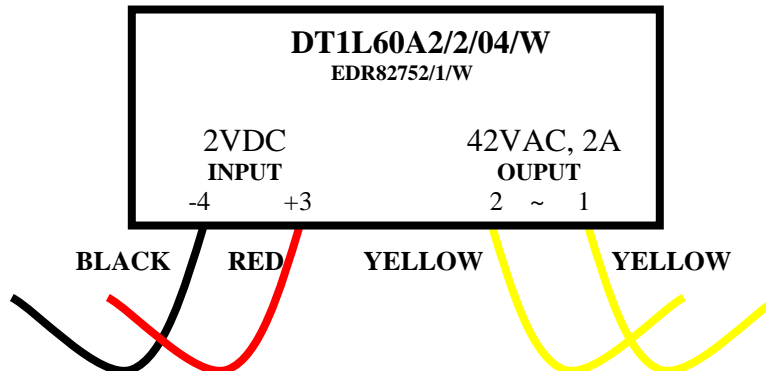

Our relays/switches manufactured with for either a pins for PC board soldering, a screw-type terminals and wires. For ordering a relay with wire, just add "W" at the end of the part number for "wire" and tell us how long the wire should be and the length of the stripped end.

Switching time test vs. the control current – Load is 10VDC, 2A and the pulse duration is 1.0 mS

Control current is 10 mA or about 3.3 VDC

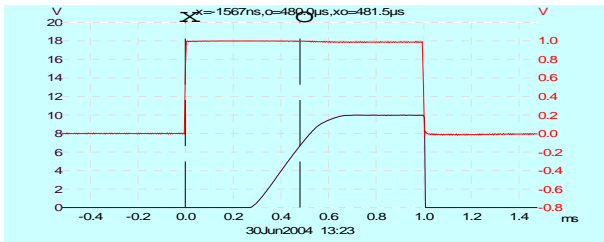

Figure 10. Turn-on delay is 481.5 μs

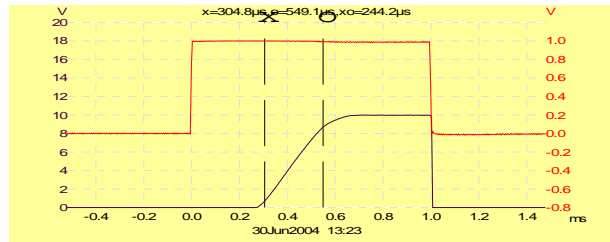

Figure 11. Rising time is 244.5 μs

Control current is 20 mA or about 5.5 VDC

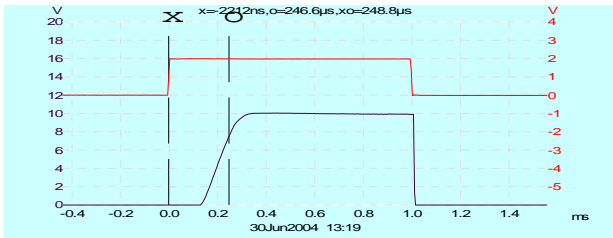

Figure 12. Turn-on delay is 248.8 μs

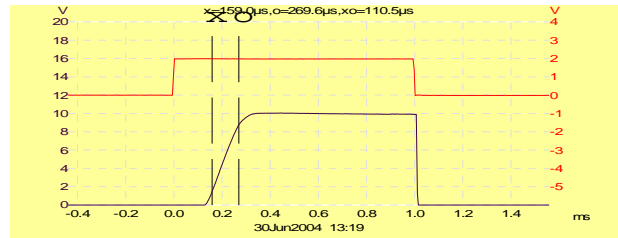
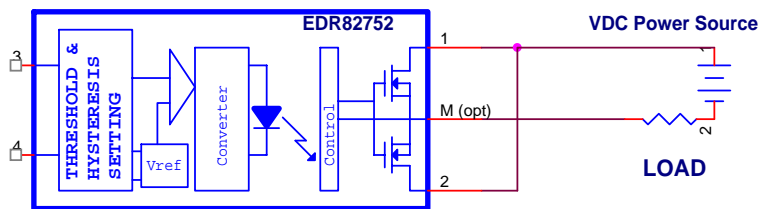

Figure 13. Rising time is 110.5 μs

**OUTPUT TERMINALS and DC or AC/DC power hook-up**

A device manufactured with three output terminals to give a customer flexibility to control either a DC or AC/DC power. A power handling (current rating) is almost double of an AC rating.



Here is an example of double current for a DC power handling applications.

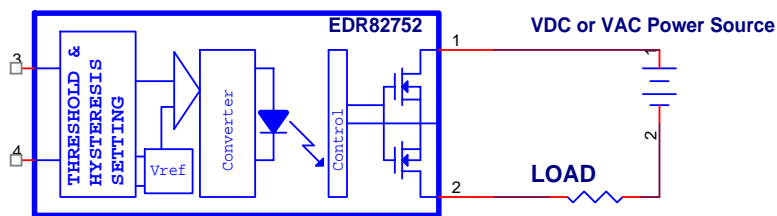

A relay can be used to control either AC or DC power.

# Solid State Relay for a high noise environment

## 1-Form A, SPST-NO Solid State Relays

<u>Model Number</u>	<u>Package</u>	<u>Operating Voltage</u>	<u>Id (A) cont.</u>	<u>Idm (A)</u>	<u>Ic (mA)</u>	<u>p/n</u>
DT1L30D12/xx	SIP4, mini	0 – 30 VDC	12 A rms	300	85	EDR82740/x
DT1L30D05/x	SIP4, mini	0 – 30 VDC	1 A rms	6.8	4	EDR82741/x
DT1L55D10/xx	SIP4, mini	0 – 55 VDC	10 A rms	200	80	EDR82742/x
DT1L60D5/xx	SIP4, mini	0 – 60 VDC	5 A rms	120	40	EDR82743/x
DT1L60D3/xx	SIP4, mini	0 – 60 VDC	3 A rms	60	10	EDR82744/x
DT1L60D04/xx	SIP4, mini	0 – 60 VDC	0.4 Arms	5	3	EDR82745/x
DT1L100D2/xx	SIP4, mini	0 – 100 VDC	2 A rms	100	30	EDR82746/x
DT2L100D10/xx	SIP4	0 – 100 VDC	10 A rms	180	60	EDR82747/x
DT1L200D2/xx	SIP4, mini	0 – 200 VDC	2 A rms	96	28	EDR82748/x
DT2L500D1/xx	SIP4	0 – 500VDC	1.3 A rms	30	20	EDR82749/x
DT1L30A11/xx	SIP4, mini	+/- 30VDC (21 VAC)	11 A rms	120	50	EDR82750/x
DT1L55A8/xx	SIP4, mini	+/- 55VDC (38 VAC)	8 A rms	160	60	EDR82751/x
DT1L60A2/xx	SIP4, mini	+/- 60 VDC (42 VAC)	2 A rms	5	3	EDR82752/x
DT1L75A4/xx	SIP4, mini	+/- 75 VDC (52 VAC)	4 A rms	120	20	EDR82753/x
DT1L100A2/xx	SIP4, mini	+/- 100 VDC (70 VAC)	2 A rms	50	20	EDR82754/x
DT2L100A5/xx	SIP4	+/- 100 VDC (70 VAC)	5 A rms	80	30	EDR82755/x
DT1L200A2/xx	SIP4, mini	+/- 200 VDC (140 VAC)	2 A rms	48	20	EDR82756/x
DT1L350A08/xx	SIP4	+/- 350VDC (225 AVC)	0.8Arms	4	1.7	EDR82757/x
DT2L500A1/xx	SIP4	+/- 500 VDC (350 VAC)	1.1 A rms	25	8	EDR82758/x
DT3L500A6/xx	SIP4	+/- 500 VDC (350 VAC)	6 A rms	100	40	EDR82759/x
DT1L600D06/xx	SIP4 mini	0 – 600 VDC	0.6A	3	.9	EDR82760/x
DT1L650D09/xx	SIP4 mini	0 – 650 VDC	0.9 A rms	6.8	2	EDR82761/x

## 1-Form B, SPST-NC Solid State Relays

<u>Model Number</u>	<u>Package</u>	<u>Operating Voltage</u>	<u>Id (A) cont.</u>	<u>p/n</u>
DT1L30D6/xx/C	SIP4, mini	0 – 30 VDC	6 A rms	EDR82762/x/C
DT1L55D2/xx/C	SIP4, mini	0 – 55 VDC	2.3 A rms	EDR82763/x/C
DT1L100D06/xxC	SIP4, mini	0 – 100 VDC	0.65 A rms	EDR82764/x/C
DT1L250D04/xx/C	SIP4 mini	0 -- 250VDC	0.4 A rms	EDR82765/x/C
DT1L150A02/xx/C	SIP4 mini	150AVC	0.2 A rms	EDR82766/x/C

All relays can be made in a panel mount box (0.82”H x 2.7”L x 2.0”W), please replace “D1” or “D2” with “D7”

The speed and frequency properties of the above relays resemble the p/n EDR82653. There is some differences between varies relays, and it mostly depends on the output power. Please request a specific data sheet if needed.

*In the same packages, we manufacture a family of miniature, low power Solid State Relays, built with MOSFETs. Those relays designed for an extremely small input control current. Only 3.0 mA @ 2.6 VDC required to operate. Please request a data sheet 7090 for p/n EDR82804. Relays were designed as a replacement of a SSR with a TRAIC or SCR output in applications where a low power consumption and low leakage current are must. Cost of a Solid State Relay is very much tied to an ordered volume, in most cases a relay costs in low teens in order of 1000 or more. We charge no production set-up fee for an order of 100 and above for any type (input and output specifications) Solid State Relay/Switch and Solid State Breaker.*

**NOTE:** A part description might change from time to time. We are running out of descriptive options and have no choice but add more letters. The part’s description will be marked according to the updated order instruction below but p/n EDRxxxxx will stay the same.

# Ordering Instruction for EDR's brand of Fast Relays/Switches

1   2   a   b   c   e   f   /h   /i   /k   /z   /0   /v

- (1)            **D**            for SPST devices  
                   **H**            for a SPDT/DPST and ½ bridge drivers  
 (2)            **T**            for a device with a precision threshold input

**(a) Package dimensions**

- 1            0.615”H x 1.48”L x 0.290”W  
 2            1.15”H x 1.75”L x 0.4”W  
 3            1.15”H x 1.75”L x 0.8”W  
 4            1.15”H x 2.0”L x 0.92”W  
 5            1.15”H x 2.8”L x 1.15”W  
 6            DIP24, 0.375”H x 0.925”L x 0.53”W  
 7            panel mount, 0.82”H x 2.7”L x 2.0”W  
 8            DIP16

**(b) Speed - A device's ability to turn ON/OFF output terminal(s) per second**

- L            a low speed relay/switch, rated DC - 2 KHz, direct driving control, SIP4  
 A            a low speed I/O relay/switch, AC input relays, SIP4  
 N            a medium speed relay/switch, rated DC - 25 KHz, direct driving control, SIP4  
 G            a medium speed relay/switch, rated DC - 25 KHz, low current control and power, SIP5  
 F            a fast relay/switch, rated DC - 150 KHz, low current control and power, SIP5  
 S            a super-fast relay/switch, rated DC - 1.4 MHz, low current control and power, SIP5  
 U            a super-fast relay/switch, rated DC - 1.2 MHz, direct driving control, SIP4

**(c) Voltage - A maximum allowed voltage between output terminals**

It must be replaced with any of offered voltage, 30VDC, 45VDC, 75VDC, 100VDC, 200VDC, 500VDC, 650VDC, 800VDC, 900VDC, 1000VDC and 1100VDC, 1400VDC and 1700VDC.

**Note:** In an “AC” -relay a voltage specified a peak-to-peak maximum voltage and the maximum VAC can be calculated by multiplying a maximum allowed voltage by factor of 0.7.

**(e) A relay can be use to control DC or AC/DC power**

- A            - a relay/switch designed to switch/chop an AC power  
 C            - a relay/switch with a normal close contacts  
 D            - a relay/switch designed to switch/chop a DC power

**(f) A maximum allowed RMS CURRENT (Ampere) without a heat sink.**

**(h) We offer several standard control voltages 5VDC, 12VDC, 24VDC, 48VDC, 3-20VDC and 18-38VDC.** Please specify the input control voltage, as for example D1L30D12/xx. Replace xx with a 3, 5, 12, 24, 48, 3-20 and 18-38 that is for 3VDC, 5VDC, 12VDC, 24VDC, 48VDC, 3-20VDC and 18-38VDC. Respectful control voltage represented at the end of part number in the following way, for an example EDR82653/1 and EDR82653/8. Both relays are almost the same and difference is only an applied control voltage, “1” if for 3VDC and “8” is for 18-38VDC;

<u>Control Voltage</u>	<u>Representation</u>	<u>Control Voltage</u>	<u>Representation</u>	<u>Control Voltage</u>	<u>Representation</u>
3VDC	1	5VDC	2	12VDC	3
24VDC	4	48VDC	5	26VDC	6
3-20VDC	7	18-38VDC	8	90-120VAC	9

**(i) A power supply required for a relay with an internal DC/DC converter. We offer several standard voltages 5VDC, 12VDC, 24VDC and 48VDC.**

**(k) Output terminals configurations**

- “1” or nothing            SPST-NO or 1 Form A output terminals  
 “2”                            SPST-NC or 1 Form B output terminals  
 “5”                            SPDT or 1 Form C output terminals  
 “T”                            TOTEM output, break-before-make termination or NO-NO  
 “7”                            DPST-NO or 2 FORM A, normal open terminals  
 “8”                            DPST-NC or 2 FORM A, normal close terminal  
 “9”                            DPST-NC/NO or 2 FORM A, normal close and normal open terminals

**(z) A relay/switch built with following standard isolations**

- “L” type relay is 2500 V  
 “N” type relay is 3000V, 4000VDC (“H4”) and 5200 (“H5”) VDC.

**(0) Screening option, (NONE) for industrial, B for Class B, and S for Class S**

**(v) a Veri-Slope option.**

**Examples:**

- D3F1000D3/4-32/5 - a fast relay/switch designed to work with up to 1000 VDC and capable of 3 Ampere of rms. A control voltage can be any from 4VDC until 32VDC and required 5VDC to operate properly, SIP5 package.  
 D3N500A10/12/12 - a medium speed relay/switch designed to withstand 500VDC peak-to-peak or 350VAC and 10 Ampere of rms. A control voltage is 12VDC and the power supply is 12VDC, SIP4 package.